

PRIMUS Diverter Shower Mixer

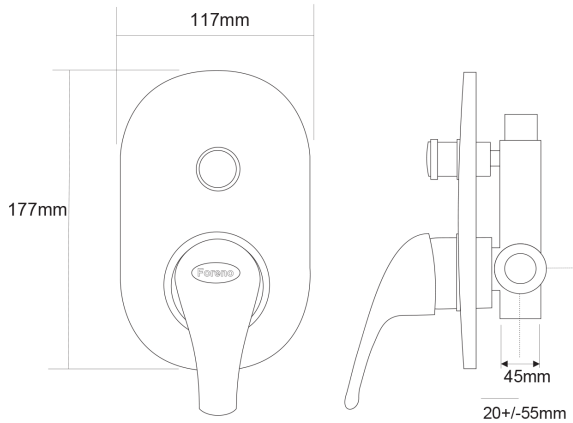

PRODUCT CODE

PDC7

COLOUR/FINISHES

Chrome

PRESSURE TYPE

Mains Pressure only

MIN. PRESSURE

150kPa

MAX. PRESSURE

500kPa (As per NZ Building Code AS/NZ 3500.1)

MAX. TEMPERATURE

65°C

PLUMBING CONNECTION

15mm

REPLACEMENT PART/S

Mixer Handle – FORPT21

Specifications and dimensions are subject to change without notice.

Installation instructions are available from the product page on www.foreno.co.nz

Foreno Tapware products are in full compliance with the requirements as set out in the New Zealand Building Code: www.foreno.co.nz/building-code-clauses/

This product is not subject to a warning or ban under section 26 of the Building Act 2004.