

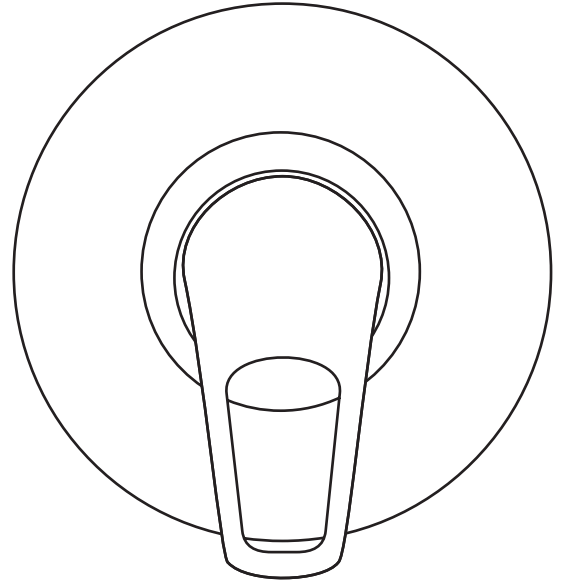

FORENO.

Loop Lever Shower Mixer FSM6



9 421009 512560

Congratulations on your purchase of this high quality product from Foreno Tapware.
Please read the following before installation and retain (along with your receipt) for future reference.

TECHNICAL SPECIFICATIONS

Suitable for All Pressures

Minimum Pressure = 35kPa

Maximum operating Pressure = 500kPa

Maximum operating Temperature = 65 deg. Celsius

For domestic use only.

CONFIGURATION

Mains Pressure systems Remove the insert from the cold inlet (marked with a 'C') prior to installation.

Unequal Low systems Install as supplied.

Equal Low systems Prior to installation, remove the valve inserts from both inlets.

NB: Only slide showers that are equipped with a large internal bore hose and open flow single function handset will work effectively with this shower mixer. We recommend the FSL8 MonoJet Slide Shower for optimum performance.

INSTALLATION

Installation must comply with Section 5.4 of AS/NZS 3500 Standard with regard to Isolating stop cock use. Shower mixers must be water tested with the outlet open, to prevent damage to cartridge seals; due to back pressure.

All pipe work must be flushed prior to the installation of this mixer, accessible inline filters must be installed in the pipework for both the hot and cold inlet supply to prevent particles from damaging the ceramic cartridge.

Back Flow Prevention: Where back flow prevention is required, install our Back Flow Prevention Valve at the supply elbow hose connection of the handpiece.

Any water seepage ex- the cartridge cavity opening can be stopped by retightening the large brass retaining nut.

For pressures exceeding 500kPa, install a pressure reducing valve.

Failure to do so will void the warranty.

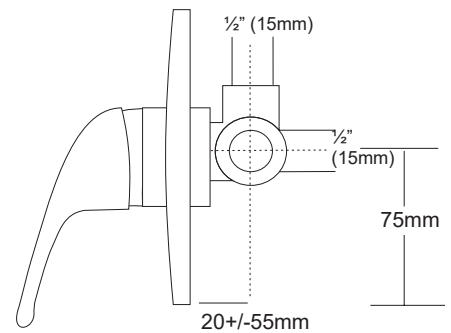

ATTACH PROOF OF PURCHASE HERE

If you have performance issue please check there are no flow restrictors between the hose and the handpiece or the hose and the shower elbow. Remove any restrictors with rubber washers.

Plumbers Note: Do not pressure test this mixer under static pressure.

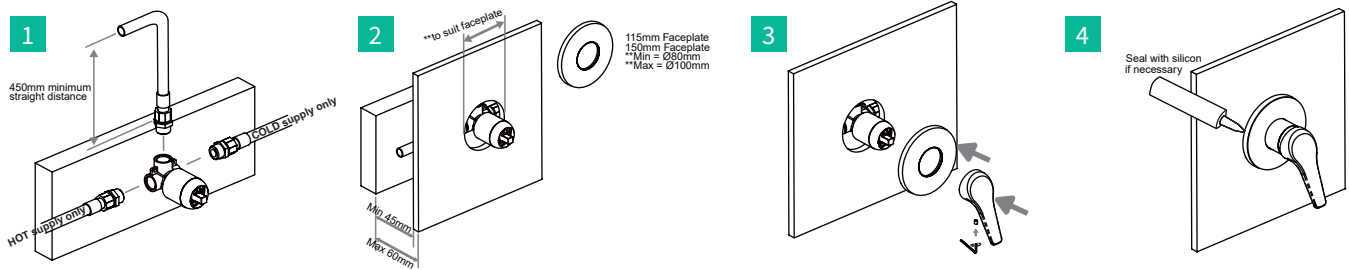

TROUBLESHOOTING

1. Is the lever between 7 and 8 O'clock? When installed correctly the lever should be close to 7 O'clock position, at 38°C, delivering about 6L per minute, where the relative hot/cold pressures are not greater than 10:1. We recommend installing the supplied Needle Valve if the cold pressure is greater than 500kPa or there is a greater than 10/1 ratio of cold to hot kPa (The needle valve should be about an 1/8th turn open).
2. If the lever is beyond 8 O'clock position, it is likely:
 - One of the valve inserts has been removed from the hot/cold ports;
 - The supply elbow has a restrictive bore (i.e. less than 10mm);
 - The supply hose has a bore size less than 9.5mm;
 - The handpiece is not a free-flow single function model
 - The WELs restrictor hasn't been removed.
 - The Pressure reducing valve has not been readjusted (the feed valve on the LP Hot water cylinder should always be readjusted when installing a new mixer, because the head pressure drops over time. To readjust the Feed Valve (Pressure reducing valve) – turn the adjuster screw clockwise until the first drips appear from the relief pipe (protruding from the roof) or relief valve then back it off half-a-turn and re-secure the locking nut.
3. If the hot/cold mix is temperamental where the lever position is within 7-8 O'clock position, either the hot or cold pressures will just require a slight tweak.
4. Check that the hot and cold supply lines have not been incorrectly plumbed in, i.e. such as the cold supply connected to the hot inlet and hot supply connected to the cold inlet. This is especially bad for Unequal Low systems as the hot port on the shower mixer body can enlarge meaning that the valve inserts will also need to be swapped.
5. When using with Unequal Low systems, it needs to be remembered the requirement for a minimum of 450mm of straight outlet pipe, before any bends.

WARRANTY

Please refer to our website for warranty information: www.foreno.co.nz/warranty

In the unlikely event that this product fails during its warranty period, phone our Customer Service team immediately on 0508 FORENO (0508 367 366) – as unauthorised removal of the product may void the warranty.

CARE AND MAINTENANCE

When cleaning your Voda product (including chrome, stainless steel, coloured or any other surface coating) you must not use any type of astringent, abrasive or citric cleaners.

We recommend using only a soft, damp cloth and on occasion a mild soap solution. Try to avoid excessive scrubbing as this could cause damage and void your warranty.

PROUD PARTNER AND SUPPORTER OF MASTER PLUMBERS, GASFITTERS AND DRAINLAYERS

